

FOR SALE/LEASE

CLASS "A" OFFICE

4200 Munson St NW - Canton, OH 44718

Belden Village

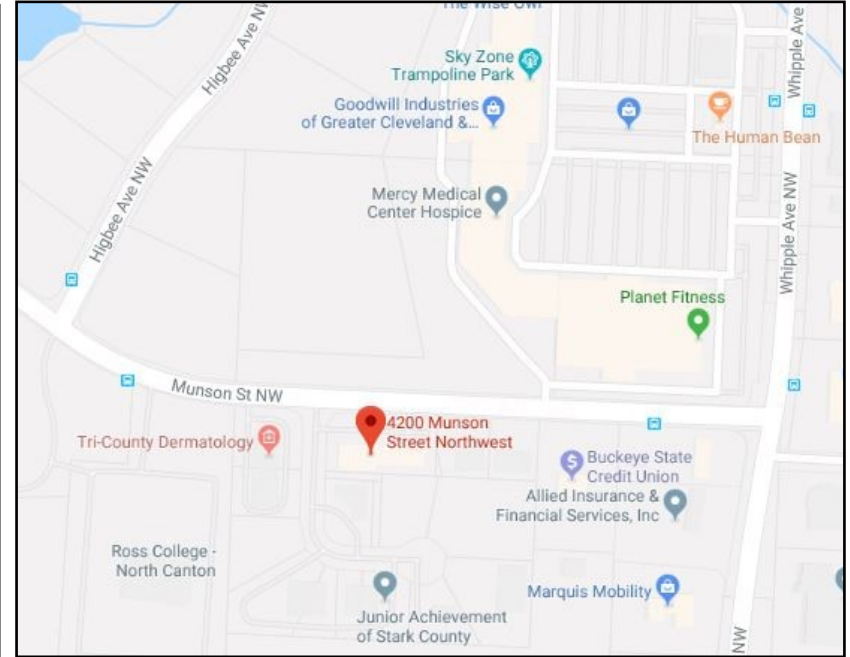

INFORMATION:

Building Size----- 11,030 Sq. Ft.
Year Built ----- 1997
Land Area ----- .93 Acres
County----- Stark
Township ----- Jackson
Zoning ----- B-1 Office
Parcel No. ----- 1702428

LEASE RATE:

Rate: ----- \$11.00/SF NNN
Net Charges:-----\$3.00/SF
Term:----- 3 - 5 Years

SALE DATA:

Sale Price:----- \$1,200,000.00
Taxes: ----- \$20,225.00

AVAILABLE SPACE:

Suite A-----1,800 Sq. Ft.
Suite B-----4,200 Sq. Ft.
Suite C-----2,800 Sq. Ft.

DETAILS:

- Wonderful location
- Great buy for Owner/User
- New roof and new parking lot
- Very well maintained

For More Information, Contact:

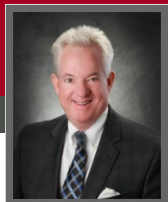

TOM JACKSON

Mobile: 330.418.1145

Office: 330.494.4411 Ext. 101
tom@tomjacksonrealty.com

4706 Douglas Circle NW
Canton, OH 44718
Office: 330.494.4411

www.TomJacksonRealty.com



© 2019 Tom Jackson Commercial Realty. We obtained the information above from sources we believe to be reliable. However, we have not verified its accuracy and make no guarantee, warranty or representation about it. It is submitted subject to the possibility of errors, omissions, change of price, rental or other condition, prior sale, lease or financing, or withdrawal without notice. We include projections, opinions, assumptions or estimates for example only, and they may not represent current or future performance of the property. You and your tax and legal advisors should conduct your own investigation of the property and transaction.

FOR SALE/LEASE

CLASS "A" OFFICE

4200 Munson St NW - Canton, OH 44718

Belden Village

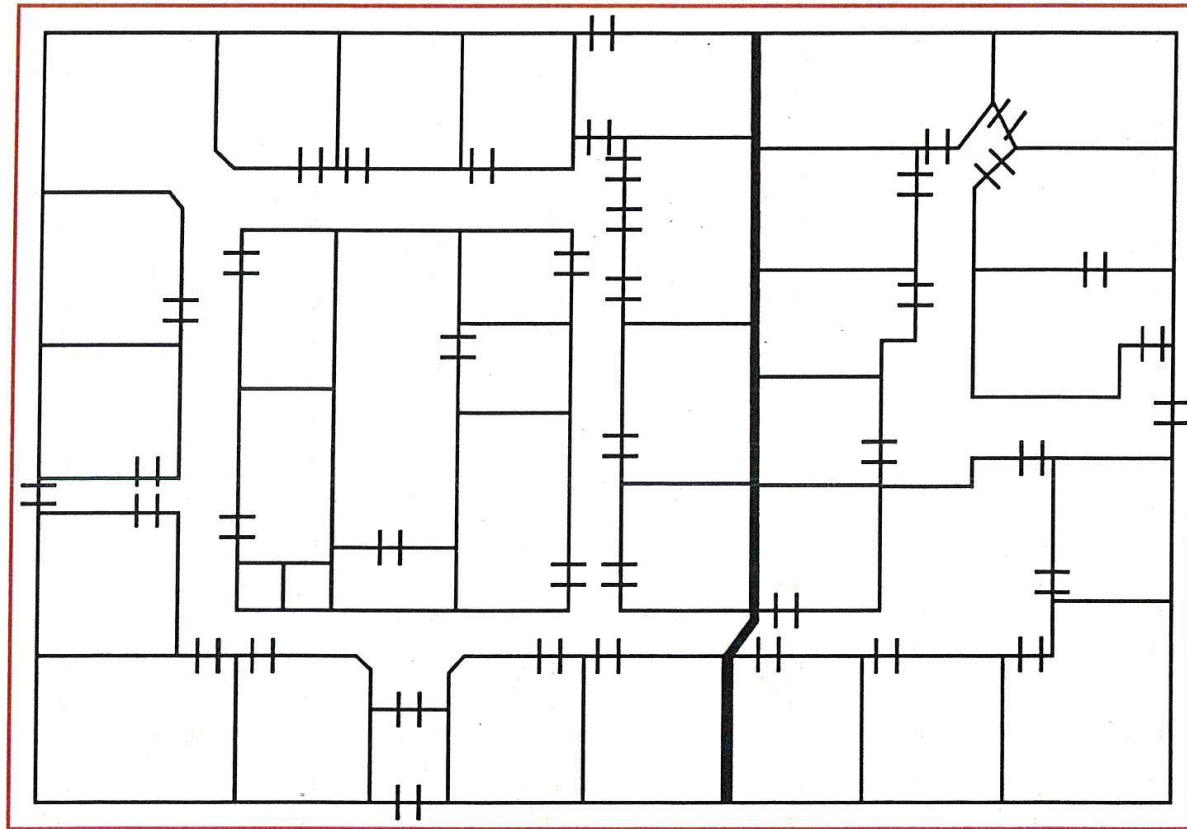

**Suite B
4,200 SF**

**Suite A
1,800 SF**

FOR SALE/LEASE

CLASS "A" OFFICE

4200 Munson St NW - Canton, OH 44718

Belden Village

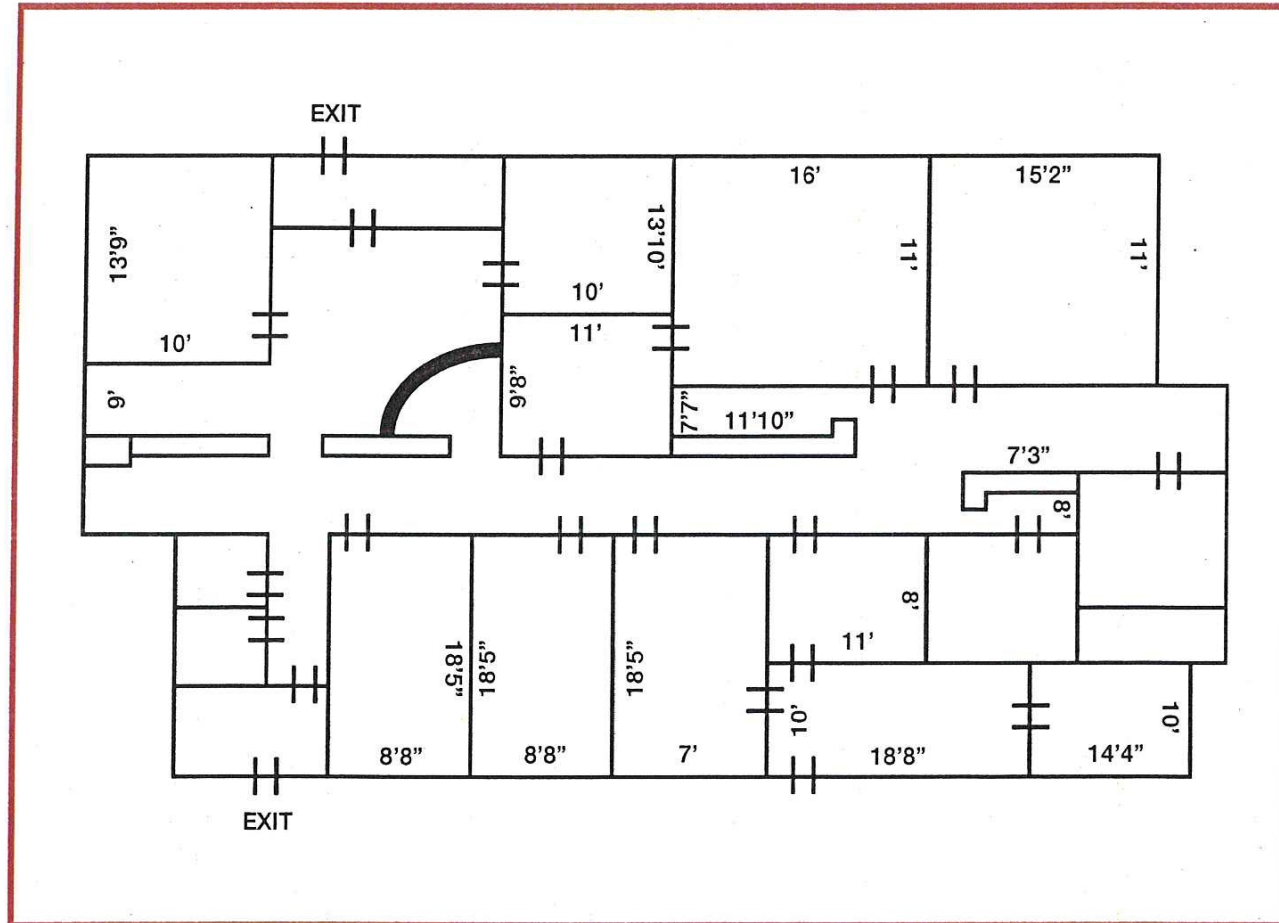

Suite C
2,850 SF

